

BECA

Natural frequency : (1)
8 to 14 Hz



DESCRIPTION

The BECA mount comprises one piece elastomer bonded to a top and bottom plate.

- Top plate : smooth or threaded (welded nut) hole.
- Bottom plate : fixing lugs or direct bearing on the ground.
- Bonded rubber.
- Domed rubber ring.
- Anti-slip bead or grooved anti-slip sole.
- Removable protective top cover : protects the rubber and distributes the load.

OPERATION

The design of the BECA mount gives the following basic characteristics :

- transverse elasticity approximately the same as the axial elasticity (equipfrequency);
- rubber works in compression;
- progressive buffer against shocks or accidental overload;
- anti-slip (may be placed directly on the ground).

Advantages

- The machine may be placed (with its mounts) directly on the ground.
- Very slim.
- Speed of fixing.
- Simple removal of the assembly.
- Extensive range : 3 hardnesses of rubber for 6 existing sizes, allowing the mounting to be optimised as a function of the load and stimulation frequency.
- A choice of 3 fixing styles.

Recommendations

- In order not to affect the suspension of the machine, all external connections must be flexible.
- BECA mount can be used for fixed, well-balanced rotating machinery, otherwise a ballasting slab should be used.

1) the indicated natural frequency, are valid for the maxi loads of the ranges of use quoted in the paragraph : TECHNICAL CHARACTERISTICS.

DIMENSIONS

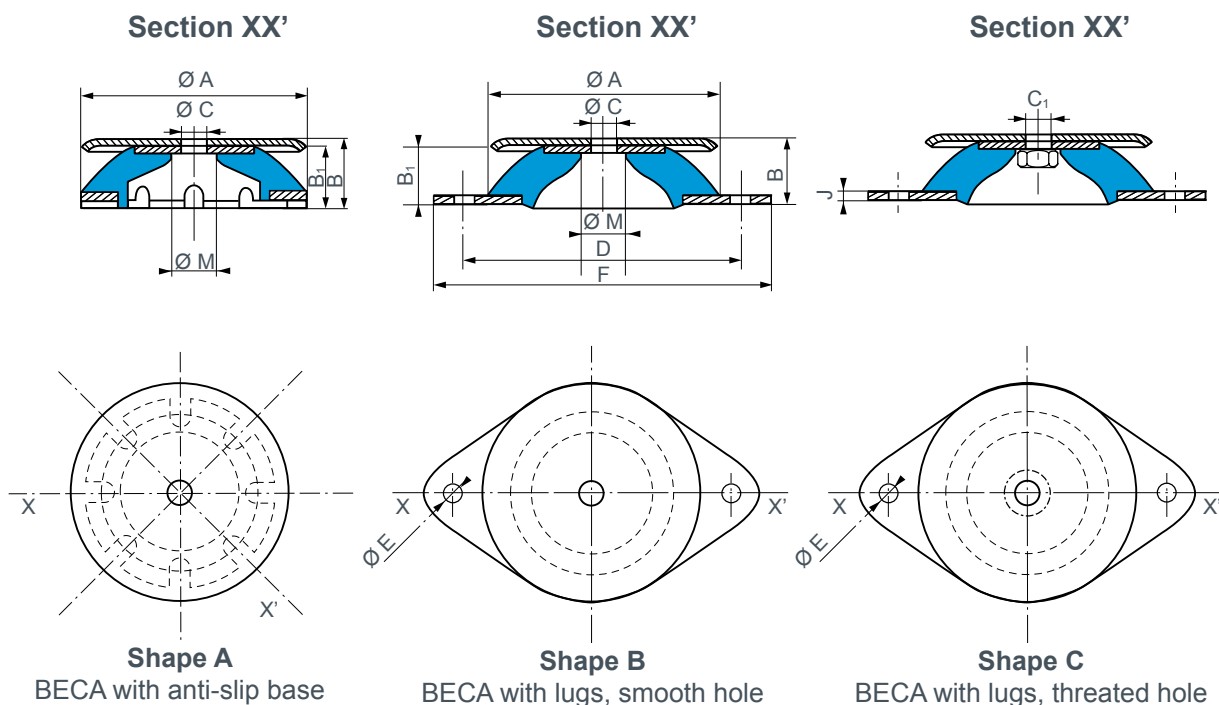

Reference			Type	Hardness	Ø A (mm)	B (mm)	B1 (mm)	Ø C (mm)	C1	D (mm)	Ø E (mm)	F (mm)	J (mm)	Ø M (mm)	Weight (g)
Anti-slip base	Diamond base														
Smooth hole Shape A	Smooth hole Shape B	Threaded hole Shape C													
-	-	533641*	Ø 40	45.60	40	20	18	-	M6	52	6,2	64	2	19	50
-	-	533661	Ø 60	45.60.75	60	24	22,5	-	M6	76	6,2	90	2	18	140
-	533581	533681	Ø 80	45.60.75	80	27	25	8,1	M8	100	8,2	120	2	22	250
533108	-	-	Ø 100	45.60.75	100	30	28	10,2	-	-	-	-	-	22	420
-	533109	533609	Ø 100	45.60.75	100	27,5	25,5	10,2	M10	124	10,2	148	2,5	22	460
533151	-	-	Ø 150	45.60.75	150	41	38	14,2	-	-	-	-	-	34	1220
-	533152	533652	Ø 150	45.60.75	150	39	36	14,2	M14	182	12,2	214	4	34	1340
533202	-	-	Ø 200	45.60.75	200	46	42	18	-	-	-	-	-	44	2750
-	533203	533623	Ø 200	45.60.75	200	44	40	18	M18	240	14,5	280	5	44	3030

See current price list for availability of items.

OPERATING CHARACTERISTICS

Type	Hardness	Nominal static load (daN)	Deflection (mm)	Type	Hardness	Nominal static load (daN)	Deflection (mm)
Ø 40	45	1 - 4	2	Ø 150	45	30 - 130	7
Ø 40	60	2 - 10	2,5	Ø 100	60	40 - 160	4
Ø 60	45	3 - 15	3	Ø 100	75	50 - 220	4
Ø 60	60	6 - 25	3	Ø 150	60	60 - 250	7
Ø 60	75	11 - 45	3	Ø 150	75	85 - 350	6
Ø 80	45	11 - 45	4,5	Ø 200	45	125 - 500	7
Ø 80	60	20 - 80	4,5	Ø 200	60	200 - 825	7
Ø 100	45	22 - 90	4	Ø 200	75	310 - 1250	6
Ø 80	75	30 - 120	4				

LOAD/DEFLECTION CURVES IN AXIAL COMPRESSION

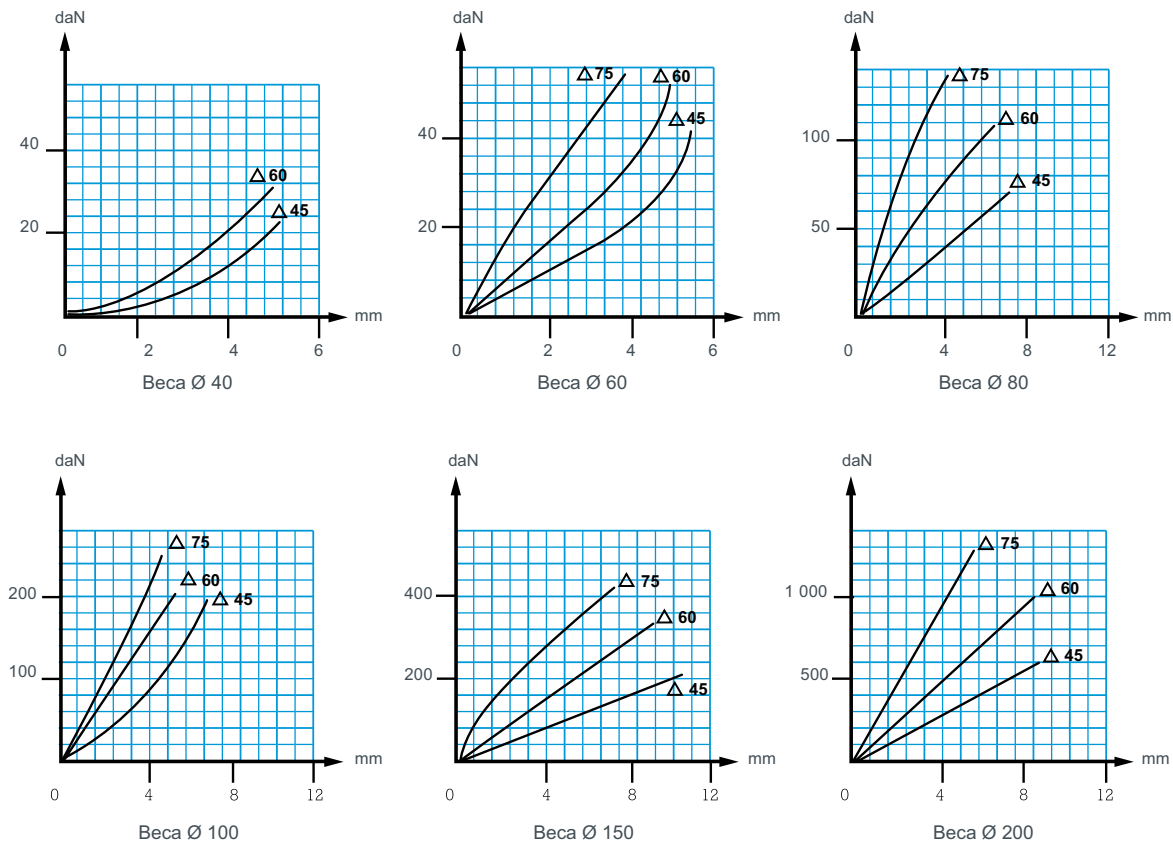

ASSEMBLY

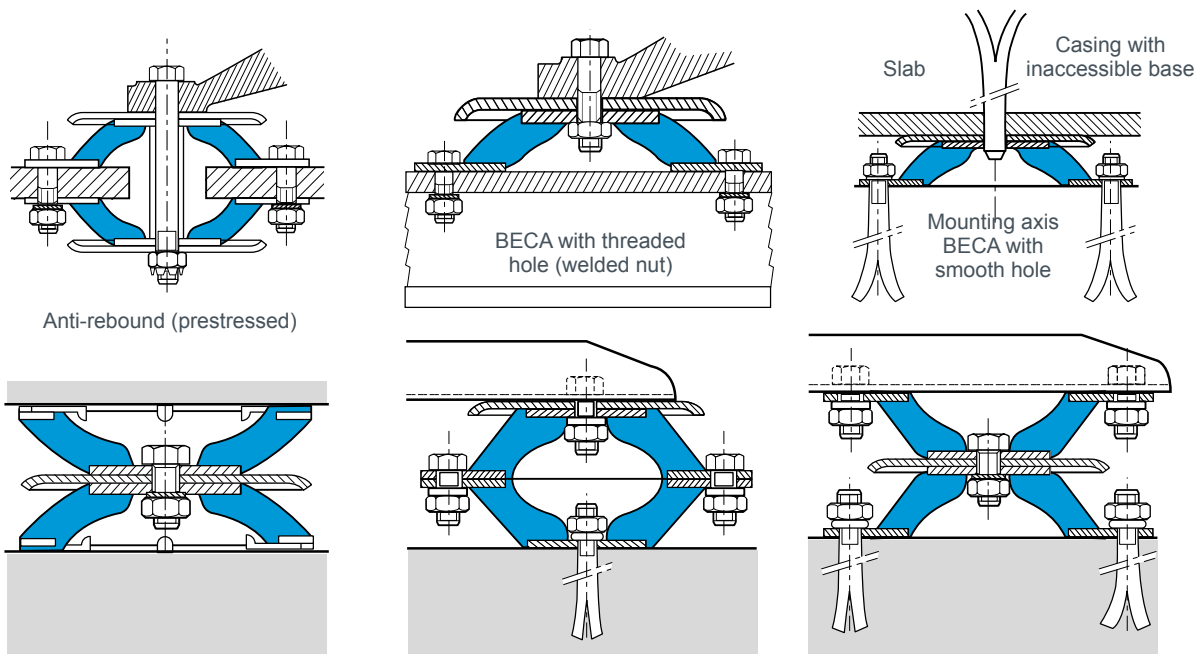

BECA mounts in tandem (to double the deflection)

All of our mounts are identified by conventional markings, either a paint spot or figures indicating the hardness: grey = hardness 45, green = hardness 60, blue = hardness 75.